

Hydraulic Circuit
P, T = G 3/8

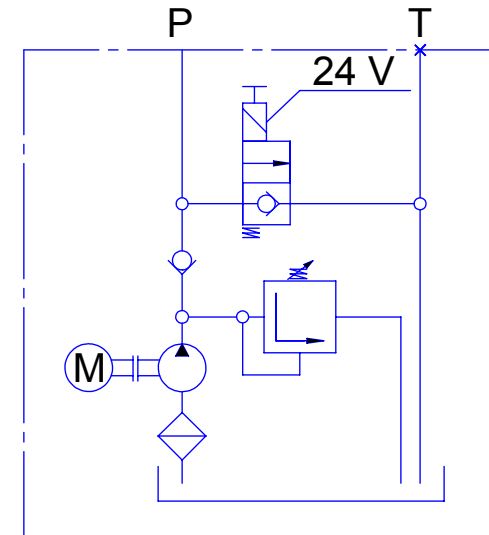
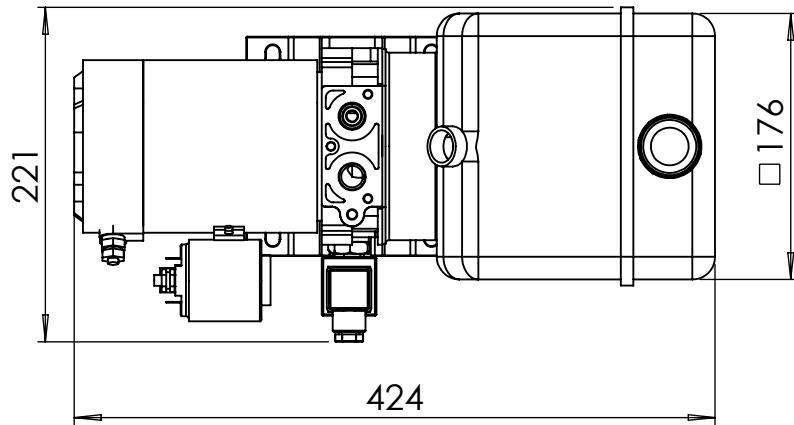

- Poppet valve is without coil
- Popet valfi bobinsiz takiniz.

ELECTRIC MOTOR

PUMP & OIL TANK

MAX. PRESSURE

Power: 2 kW

Pump displacement: 2.1 cc/rev

P: 210 bar

Voltage: 24 V DC

Tank Capacity: 4 liter plastic, horizontal

Notes:

DESIGNED BY	NAME	SIGNATURE	DATE	MATERIAL:

DESCRIPTION	A4
MINI POWER PACK	