

Introduction

► Feature

| | |
|-------------------------------------|--|
| Line pull (1 st layer): | 4,535 kg / 10,000 lb (SAE J706 rating) 4,300 kg (EN 14492-1 rating) first layer of rope |
| Line speed (1 st layer): | 14 mpm / 46 fpm at 60 l / min (15.9 g / min) |
| Operation pressure: | 150 bar / 2,175 psi |
| Brake: | Drag brake and over-center valve provided for full 100% braking |
| Clutch (freespooling): | Pull and turn extended T-handle for rapid wire rope payout |
| Recommended wire rope: | 11 mm x 27 m, 1960 N/mm ² grade, A minimum breaking strength of 84.4 KN required |
| Hydraulic system: | PTO/power take off unit driven pump |

► Read this manual carefully

You should carefully read and understand this manual before operating it. Careless winch operation may result in personal injury hazards or property damage.

► Information requesting or parts ordering

Please specify the followings information:

- Winch PN
- Serial number
- Part description
- Part number
- Quantity for each part

Installation

Before using the winch, make sure all components have no corrosion or damaged; the environment should be clear and dry.

► Mounting

- Winch shall be mounted on a flat and hard surface.
- Winch should be mounted as closed to center and as perpendicular as possible to the direction of the line pull.
- Wire rope shall be wound in an under-wound

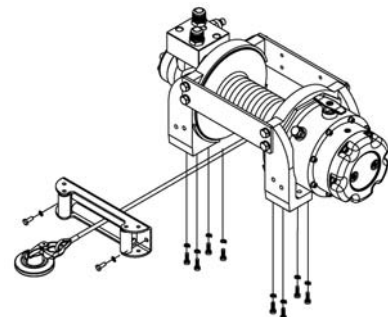

orientation only.

- Eight (8) M10 x 1.5 pitch 8.8 grade w/44 N-m torque setting (maximum) high tensile steel bolts must be used in order to sustain the loads imposed on the winch mounting.
- It is always preferred to use both tie bars in the final installed configuration.
- If there is a rope pileup on one end of the drum, reverse the winch to relieve the load and move your anchor point further to the center of the vehicle. Then you can rewind for a neat layer of the rope.

Compliance with EN 14492-1

The winch HV-10 complies with European Standard of EN-14492:2006 Power-Driven Winches and the latest Machinery Directive: 2006/42/EC provided that the OWNER or END USER complies with all responsibilities described below.

1. Refer to the Instruction Manual to install winch for safe winching operation..
2. Fit a wire rope at 11 mm x 27 m grade 1960 N/mm² or EIPS with a minimum breaking strength of 84.4 KN to comply with EN ratings;
 - * Rope drives with steel wire rope shall be dimensioned
 - * At least 2:1 wire rope working coefficient for the first rope layer.
 - * At least 10:1 D/d ratio to the centre of the rope
 - * At least 1.5 layer of wire rope freeboard.
3. The wire rope must be painted red for 1.6 m on both ends and at least five (5) wraps of wire rope remained around the drum to comply with EN ratings;
 - * At least two rope windings on the drum.
 - * Rope attachment to withstand 2.5 x the remaining static force.
4. Fit a pressure relief valve to comply with rated capacity limiter.
5. Fit an emergency stop valve to comply with emergency stop function.
6. Fit a hook with a safety latch to comply with a safety hook.

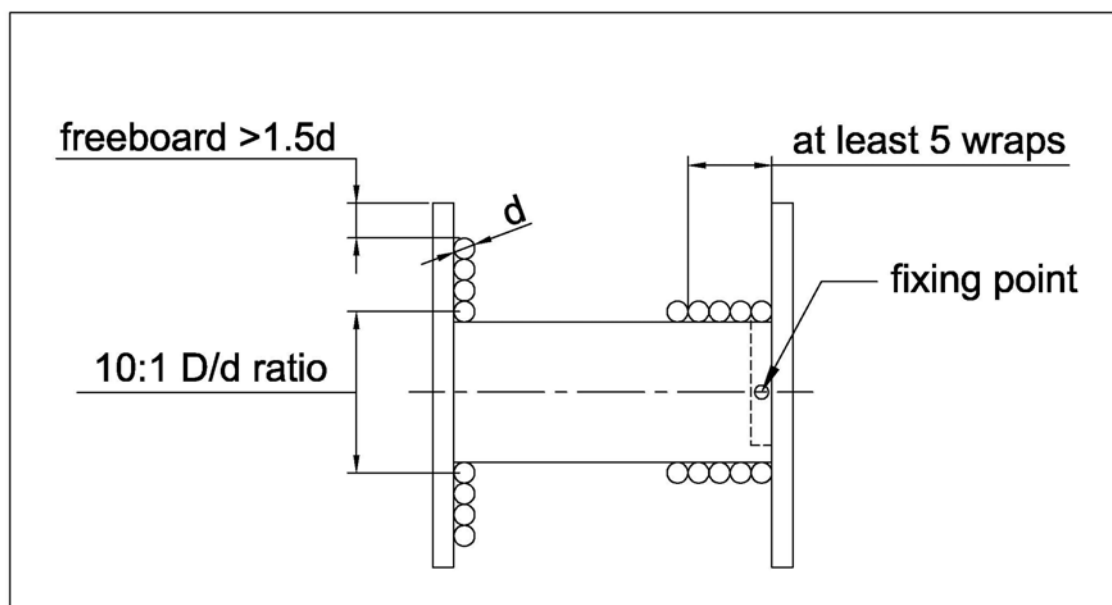

Warning

- This winch shall only be used for vehicle recovery or for pulling and lowering boats off trailers.
- The rated line pull and speed are based on the first layer of rope on the drum.
- The rope winding on the drum shall remain 5 wraps from the drum.

Warranty

Comeup Industries Inc. takes the responsibility for all parts and components to be free from defects in materials and workmanship appearing under normal use for one year from the date of purchase.

Parts List

| Item No. | Description | Part No. | Qty |
|----------|-------------------------------|----------|-----|
| 1 | Hydraulic motor kit | 880162 | 1 |
| 2 | Over center valve | 880145 | 1 |
| 3 | Motor support rack | 882093 | 1 |
| 4 | Tie bar kit | 880163 | 1 |
| 5 | Tie bar kit | 881172 | 1 |
| 6 | Drum bushing | 880048 | 2 |
| 7 | Drum kit | 881173 | 1 |
| 8 | Connecting shaft kit | 880165 | 1 |
| 9 | Gearbox support rack | 881135 | 1 |
| 10 | 2 nd stage carrier | 881253 | 1 |
| 11 | 1 st stage carrier | 880153 | 1 |
| 12 | Ring gear | 880154 | 1 |
| 13 | 1 st shaft kit | 880155 | 1 |
| 14 | clutch kit | 880156 | 1 |
| 15 | Gear box kit | 881315 | 1 |
| 16 | Drag brake kit | 880158 | 1 |
| 17 | Brake disc | 881127 | 1 |
| 18 | Brake spring | 881128 | 1 |
| 19 | Brake cover kit | 881317 | 1 |
| 20 | Roller fairlead | 880180 | 1 |

Winch Assembly

