

**Hydraulic Circuit**  
P, T = G 3/8

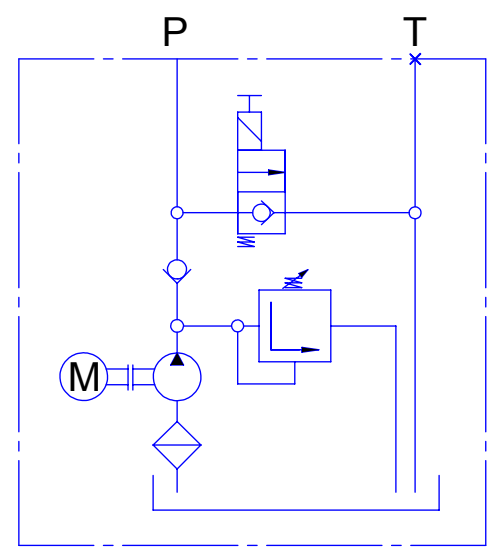
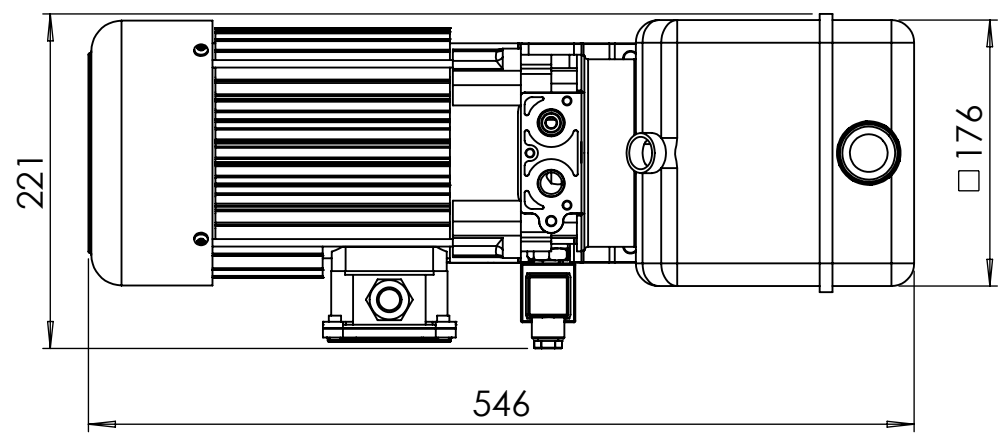

- Poppet valve is without coil
- Poppet valfi bobinsiz takiniz.

**ELECTRIC MOTOR**

**PUMP & OIL TANK**

**MAX. PRESSURE**

Power: 1.5 kW

Pump displacement: 2.7 cc/rev

P: 210 bar

Voltage: 380 V AC

Tank Capacity: 4 liter plastic, horizontal

**Notes:**

DESIGNED BY	NAME	SIGNATURE	DATE	MATERIAL:

DESCRIPTION	A4
<b>MINI POWER PACK</b>	